

ferroli

ARITERM



BIOMASS PELLET BOILERS

Ariterm Biomatic+ 20 / Biomatic+ 40

Next generation of integrated pellet boilers



NO1

best-selling pellet boiler
in Scandinavia

The Ariterm Biomatic+ is an economic, reliable and environmentally-friendly pellet boiler for heating homes and for the production of domestic hot water (DHW). There are two models available, the Biomatic+ 20 (20kW) & Biomatic+ 40 (40kW).

The Biomatic+ is designed and manufactured in Sweden, the home of biomass boilers and a country renowned for quality and for all that is best in renewable energy technology. In fact, the Biomatic+ has become the number one best-selling pellet boiler in Scandinavia and is proven to be reliable, low maintenance and exceptionally easy to install.

Key Features

- Easy to install and service – the burner and controls are all designed to be easily accessible from the front of the boiler, making installation and servicing extremely quick and straightforward.
- Integrated hot water storage – up to 173 litres at up to 90°C which means that a separate thermal store is often unnecessary.
- Combi boiler version with an integrated instant domestic hot water (DHW) generator delivering enough hot water to power two showers simultaneously from the boiler, without the need for a separate buffer tank or thermal store.
- Twin heating circuits giving the option to connect and control two independent heating circuits (e.g. a radiator circuit and an underfloor circuit) direct from the boiler.

Automatic control

The control system is specially designed for pellet combustion and allows efficient control at three different settings. The control display provides information about operational status, such as boiler temperature, flue temperature, rate of pellet consumption and warning functions etc.

Model options

Both Biomatic+ models are available in three versions – with or without the DHW generator, and with or without an optional integrated back-up immersion heater.

The Biomatic+ boilers are MCS and RHI emissions certified and are fully authorised for use in smoke controlled areas.



Ariterm BioCompPX

The compact and reliable 60kW boiler



The Ariterm BioCompPX is an extremely cost-effective, compact and reliable 60kW pellet boiler intended for large domestic and light commercial applications. It allows for continuous operation up to 60kW which makes it an excellent appliance for those with high continuous output requirements.

Key Features

- Easy to install – the burner can be mounted on either the right or left hand side, making installation design simple.
- Easy maintenance – there is a large ash space that is easily accessed from the front hatch. An automatic ash removal option is also available.
- Easy to service – the pellet burner is installed on runners, making it extremely easy to remove the boiler for servicing or cleaning.
- Combi boiler option – available with or without an integrated combi domestic hot water (DHW) generator. An immersion heater can also be installed in the boiler.
- Cascades to 120 or 180kW – designed to cascade easily providing a highly flexible and efficient solution, often at a lower cost than an equivalent single boiler.

Control System

The control system is specially designed for pellet combustion and allows efficient control at two different settings. The control display provides information about operational status, such as boiler temperature, exhaust temperature, rate of pellet consumption and warning functions etc.

The BioCompPX is RHI emissions certified and qualifies for the commercial RHI.

Please note that because the BioCompPX is larger than 45kW it is not eligible for the Domestic RHI.

Biomatic+ 20 Technical Specification

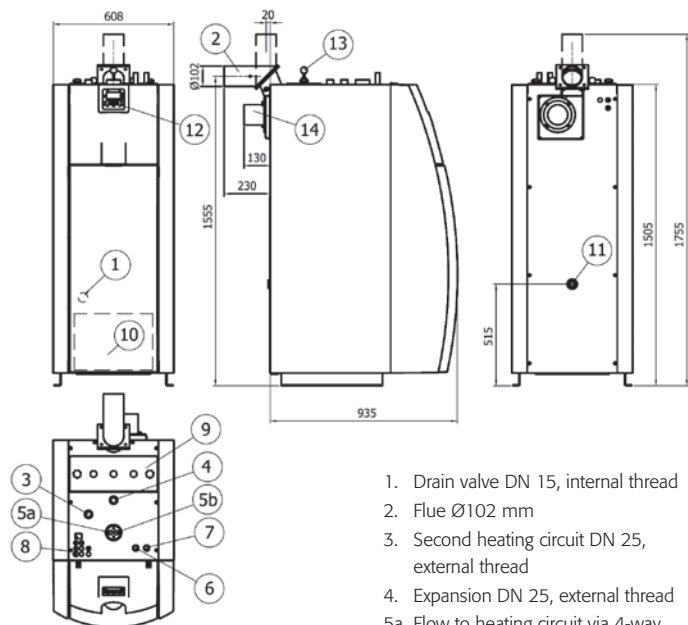

1. Drain valve DN 15, internal thread
2. Flue Ø102 mm
3. Second heating circuit DN 25, external thread
4. Expansion DN 25, external thread
- 5a. Flow to heating circuit via 4-way mixing valve
- 5b. Return from heating circuit via 4-way mixing valve
6. Cold DHW feed 22 mm Cu
7. Hot DHW supply 22 mm Cu
8. Electrical lead-ins
9. Cleaning hatch
10. Ash box
11. Return DN 25, internal thread
12. Display/keypad
13. Automatic convection cleaning
14. Flue gas fan

Included in the delivery:

- 4-way mixing valve ESBE TM 20
- Motorised head for mixing valve
- Range of cleaning tools
- Vertical/horizontal flue adaptor
- Outdoor temperature sensor
- Room temperature sensor
- Flow water temperature sensor
- Flue gas fan
- Automatic convection cleaning
- Flow sensor & silt trap (DHW generator option only)

Accessories:

- 45° flue adaptor
- 2nd heat circuit connector & control system
- Room temperature control & display unit
- Lambda control system
- GSM remote control system
- Thermal store sensor(s)

Biomatic+ 40 Technical Specification

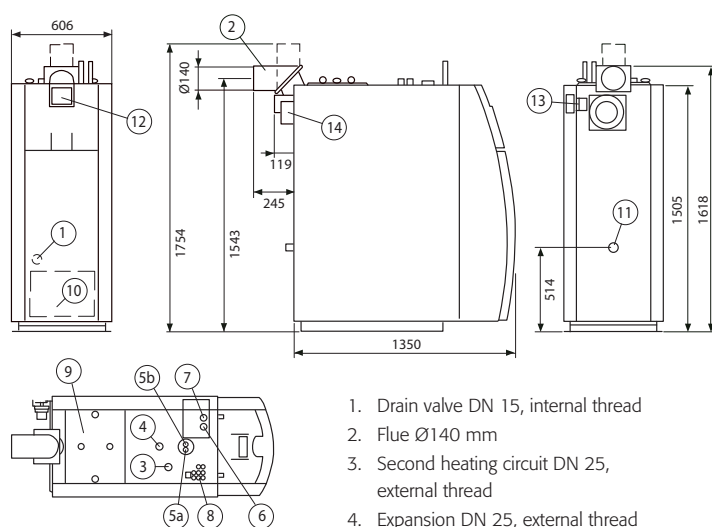

1. Drain valve DN 15, internal thread
2. Flue Ø140 mm
3. Second heating circuit DN 25, external thread
4. Expansion DN 25, external thread
- 5a. Flow to heating circuit via 4-way mixing valve
- 5b. Return from heating circuit via 4-way mixing valve
6. Cold DHW feed 22 mm Cu
7. Hot DHW supply 22 mm Cu
8. Electrical lead-ins
9. Cleaning hatch
10. Ash box
11. Return DN 25, internal thread
12. Display/keypad
13. Automatic convection cleaning
14. Flue gas fan

Included in the delivery:

- 4-way mixing valve ESBE TM 20
- Motorised head for mixing valve
- Range of cleaning tools
- Vertical/horizontal flue adaptor
- Outdoor temperature sensor
- Room temperature sensor
- Flow water temperature sensor
- Flue gas fan
- Automatic convection cleaning
- Flow sensor & silt trap (DHW generator option only)

Accessories:

- 45° flue adaptor
- 2nd heat circuit connector & control system
- Room temperature control & display unit
- Lambda control system
- GSM remote control system
- Thermal store sensor(s)

BioCompPX Technical Specification

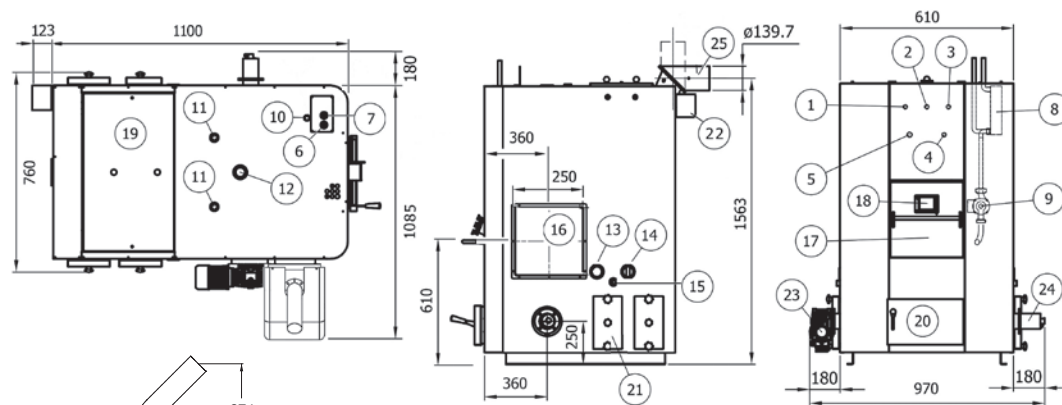

1. Spare DN15
2. Burner sensor and overheat protection
3. Spare DN15
4. Combustion chamber DN 20
5. Combustion chamber DN 15
6. Supply for DHW Ø 22 mm Cu
7. DHW flow Ø 22 mm Cu
8. Heat exchanger for DHW
9. Pump to DHW heat exchanger
10. Bleed valve for DHW heat exchanger
11. Expansion/safety valve DN 25
12. Supply DN 50
13. Immersion heater socket DN 50
14. Return DN 50
15. Draining DN 20
16. Burner opening, right or left side
17. Service hatch
18. Sight glass
19. Soot cabinet with convection cleaning
20. Ash hatch
21. Cleaning hatches
22. Convection cleaning motor
23. Motor for ash auger (accessory)
24. Ash auger (accessory)
25. Flue Ø 139 mm

Included in the delivery:

- Cleaning tools
- Vertical/horizontal flue adaptor
- Flue gas fan
- Silt filter (for DHW option)
- Automatic convection section cleaning

Accessories:

- 45° flue outlet adaptor
- Buffer tank sensors
- Ash removal system
- GSM remote control system
- Immersion heater

Technical Specifications



		Biomatic+ 20	Biomatic+ 40	BioCompPX
Output, pellets	kW	8-20	12-40	60
Immersion heater	kW	6-9 (optional)	6-9 (optional)	6-9 (optional)
Water volume, boiler	litres	140	173	175
Weight (empty)	kg	245	455	495
Rec. flue diameter	Ømm	100 (min)	140 (min)	150 (min)
Rec. flue height (guide)*	m	4	4	5
DHW flow rate (+40°C)	l/min.	20 (240l)	24 (400l)	24 (400l)
Max operating pressure	bar	1.5	2.5	3.0
Max operating temperature	°C	120	120	130
Combustion efficiency	%	91	93	93
Dimensions	mm	608 x 1065 x 1606	606 x 1350 x 1618	1270 x 1400 x 1630

Pellet Feeding



Ariterm Feedo – for reliable pellet feeding

Ariterm's Feedo pellet auger provides reliable and problem-free transportation of the pellets between the pellet store and the boiler. Feedo is designed to be used with Ariterm's range of pellet storage solutions.

The system includes a range of straight and curved sections allowing a wide range of feeding geometries between the store and the boiler.

The Feedo system is designed for very low power consumption and quiet operation. A single Feedo auger will transport pellets up to 5m. For longer runs multiple Feedo augers can be installed in series.

Pellet Storage



Ariterm PF450

Pellet volume	450 litres
Dimensions	1255(H) x 722(W) x 722(D) mm

Ariterm Pellet Storage Solutions

A wide range of indoor and outdoor pellet storage solutions are available including:

- Small manual bag-filled hoppers such as the Ariterm PF450
- Custom site-built solutions such as the Ariterm Depo system
- Indoor and outdoor fabric or steel hoppers holding up to 10 tonnes (or more).

All our storage solutions are designed to work with the Ariterm Feedo auger system.

Ask us for more details of the full range available.



Ariterm Depo System

The Ariterm Depo pellet extraction system is designed to enable the user to custom build an indoor pellet store to maximise available indoor space.

Control Units



Biomatic+ 20 & Biomatic+ 40 Control Unit

1. Switch for DHW circulation pump (if used)
2. Fuse for DHW circulation pump (if used)
3. Display
4. Overheat protection
5. Main power on/off switch
6. Operation and alarm indicator
7. Keypad with scroll & select function



BioCompPX Control Unit

The display shows the operating mode and the current boiler temperature. Explanatory text scrolls through the display every 5 seconds.

The control uses a simple single button which is either pressed or turned in order to select or scroll through the boiler functions.

Control Units are supplied with the boilers



BIOMASS PELLET BOILERS

T: 0843 479 4790 F: 0843 479 0081

sales@ferrolí.co.uk

www.ferrolí.co.uk